

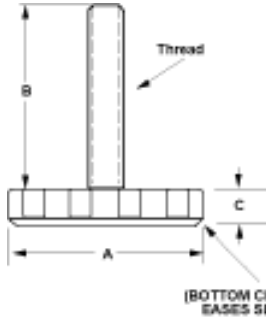

KNOB STYLE GLIDES

The IEC Knob Style Steel and Stainless Steel Glide is ideal for light and medium duty load requirements. These low-profile, solid bottom, large diameter black polypropylene base glides are perfect for leveling and stabilizing furniture, instruments, racks and appliances without the need for tools. The unique rigid design can withstand failure when subjected to "drop-tests" and excessive tilting. Useful in both feet and knob applications. Special thread lengths can be specified and easily manufactured. Top hex (-HX) and slot standard (-SL) on some sizes. Top slot can be added to any item, add (-SL) to part number.



Top Hex (-HX) and Slot (-SL)

Threaded Nylon Knob Hubs/Sleeves

These glass-filled black nylon threaded knob hubs can be used for many applications; as an adjustable height shoulder on a knob or leveler or stacked to create a sleeve to hide the threads of a leveler or knob. This will also help stabilize loads positioned near the top threads of long studs. They can also be used by themselves to create a "thru-hole" knob or as a locking nut.



* Patent Pending

BLACK NYLON THREADED KNOB HUBS

P/N	THREAD	DIA.	HEIGHT
IL80-HUB-4	1/4-20	1"	3/8
IL80-HUB-5	5/16-18	1"	3/8
IL80-HUB-6	3/8-16	1"	3/8
IL80A-HUB-4	1/4-20	1"	3/4
IL80A-HUB-5	5/16-18	1"	3/4
IL80A-HUB-6	3/8-16	1"	3/4

Steel	SS	Load	Thread	A	B	C
Steel and Stainless Steel Knob Style Glides						
IL84-6Bx1/4	IL84-6BSx1/4	1000	3/8-16	2	1/4	3/8
IL84-6Bx1/2	IL84-6BSx1/2	1000	3/8-16	2	1/2	3/8
IL84-6Bx1/2-HX-SL		1000	3/8-16	2	1/2	3/8
IL84-6Bx3/4-HX-SL		1000	3/8-16	2	3/4	3/8
IL84-6Bx1	IL84-6BSx1	1000	3/8-16	2	1	3/8
IL84-6Bx1-HX-SL		1000	3/8-16	2	1	3/8
IL84-6Bx125	IL84-6BSx125	1000	3/8-16	2	1-1/4	3/8
IL84-6Bx125-HX-SL		1000	3/8-16	2	1-1/4	3/8
IL84-6Bx150	IL84-6BSx150	1000	3/8-16	2	1-1/2	3/8
IL84-6Bx175-HX-SL		1000	3/8-16	2	1-3/4	3/8
IL84-6Bx175	IL84-6BSx175	1000	3/8-16	2	1-3/4	3/8
IL84-6Bx238	IL84-6BSx238	1000	3/8-16	2	2-3/8	3/8
IL84-6Bx238-SL		1000	3/8-16	2	2-3/8	3/8
IL84-6Bx238-HX-SL		1000	3/8-16	2	2-3/8	3/8
IL84-6Bx275-HX-SL		1000	3/8-16	2	2-3/4	3/8
IL84-6Bx338-HX-SL		1000	3/8-16	2	3-3/8	3/8
IL84-7Bx3/4	IL84-7BSx3/4	1000	1/2-13	2	3/4	3/8
IL84-7Bx1	IL84-7BSx1	1000	1/2-13	2	1	3/8
IL84-7Bx125	IL84-7BSx125	1000	1/2-13	2	1-1/4	3/8
IL84-7Bx150	IL84-7BSx150	1000	1/2-13	2	1-1/2	3/8
IL84-7Bx238		1000	1/2-13	2	2-3/8	3/8
IL86-4Bx1/4	IL86-4BSx1/4	100	1/4-20	2-1/2	1/4	3/8
IL86-4Bx1/2	IL86-4BSx1/2	100	1/4-20	2-1/2	1/2	3/8
IL86-4Bx1/2-HX-SL		100	1/4-20	2-1/2	1/2	3/8
IL86-4Bx3/4	IL86-4BSx3/4	100	1/4-20	2-1/2	3/4	3/8
IL86-4Bx3/4-HX-SL		100	1/4-20	2-1/2	3/4	3/8
IL86-4Bx1	IL86-4BSx1	100	1/4-20	2-1/2	1	3/8
IL86-4Bx1-HX-SL		100	1/4-20	2-1/2	1	3/8
IL86-4Bx125	IL86-4BSx125	100	1/4-20	2-1/2	1-1/4	3/8
IL86-4Bx125-HX-SL		100	1/4-20	2-1/2	1-1/4	3/8
IL86-4Bx150	IL86-4BSx150	100	1/4-20	2-1/2	1-1/2	3/8
IL86-4Bx175	IL86-4BSx175	100	1/4-20	2-1/2	1-3/4	3/8
IL86-4Bx175-HX-SL		100	1/4-20	2-1/2	1-3/4	3/8
IL86-4Bx2	IL86-4BSx2	100	1/4-20	2-1/2	2	3/8
IL86-4Bx275	IL86-4BSx275	100	1/4-20	2-1/2	2-3/4	3/8
IL86-5Bx1/4	IL86-5BSx1/4	500	5/16-18	2-1/2	1/4	3/8
IL86-5Bx1/2	IL86-5BSx1/2	500	5/16-18	2-1/2	1/2	3/8
IL86-5Bx1/2-HX-SL		500	5/16-18	2-1/2	1/2	3/8
IL86-5Bx3/4	IL86-5BSx3/4	500	5/16-18	2-1/2	3/4	3/8
IL86-5Bx3/4-HX-SL		500	5/16-18	2-1/2	3/4	3/8
IL86-5Bx1	IL86-5BSx1	500	5/16-18	2-1/2	1	3/8
IL86-5Bx1-HX-SL		500	5/16-18	2-1/2	1	3/8
IL86-5Bx125-HX-SL		500	5/16-18	2-1/2	1-1/4	3/8
IL86-5Bx125	IL86-5BSx125	500	5/16-18	2-1/2	1-1/4	3/8
IL86-5Bx175	IL86-5BSx175	500	5/16-18	2-1/2	1-3/4	3/8
IL86-5Bx175-HX-SL		500	5/16-18	2-1/2	1-3/4	3/8
IL86-5Bx225-HX-SL		500	5/16-18	2-1/2	2-1/4	3/8
IL86-6Bx1/4	IL86-6BSx1/4	1000	3/8-16	2-1/2	1/4	3/8
IL86-6Bx1/2	IL86-6BSx1/2	1000	3/8-16	2-1/2	1/2	3/8
IL86-6Bx1/2-HX-SL		1000	3/8-16	2-1/2	1/2	3/8
IL86-6Bx3/4-HX-SL		1000	3/8-16	2-1/2	3/4	3/8
IL86-6Bx1	IL86-6BSx1	1000	3/8-16	2-1/2	1	3/8
IL86-6Bx1-HX-SL		1000	3/8-16	2-1/2	1	3/8
IL86-6Bx125	IL86-6BSx125	1000	3/8-16	2-1/2	1-1/4	3/8
IL86-6Bx125-HX-SL		1000	3/8-16	2-1/2	1-1/4	3/8
IL86-6Bx150	IL86-6BSx150	1000	3/8-16	2-1/2	1-1/2	3/8
IL86-6Bx175-HX-SL		1000	3/8-16	2-1/2	1-3/4	3/8
IL86-6Bx175	IL86-6BSx175	1000	3/8-16	2-1/2	1-3/4	3/8
IL86-6Bx238	IL86-6BSx238	1000	3/8-16	2-1/2	2-3/8	3/8
IL86-6Bx238-SL		1000	3/8-16	2-1/2	2-3/8	3/8
IL86-6Bx238-HX-SL		1000	3/8-16	2-1/2	2-3/8	3/8
IL86-6Bx275-HX-SL		1000	3/8-16	2-1/2	2-3/4	3/8
IL86-6Bx338-HX-SL		1000	3/8-16	2-1/2	3-3/8	3/8
IL86-7Bx3/4	IL86-7BSx3/4	1000	1/2-13	2-1/2	3/4	3/8
IL86-7Bx1	IL86-7BSx1	1000	1/2-13	2-1/2	1	3/8
IL86-7Bx125	IL86-7BSx125	1000	1/2-13	2-1/2	1-1/4	3/8
IL86-7Bx150	IL86-7BSx150	1000	1/2-13	2-1/2	1-1/2	3/8
IL86-7Bx238		1000	1/2-13	2-1/2	2-3/8	3/8



Many colors available as custom option.



KNOB STYLE GLIDES

The IEC Knob Style Steel and Stainless Steel Glide is ideal for light and medium duty load requirements. These low-profile, solid bottom, large diameter black polypropylene base glides are perfect for leveling and stabilizing furniture, racks, instruments and appliances without the need for tools. The unique rigid design can withstand failure when subjected to "drop-tests" and excessive tilting. Useful in both feet and knob applications. Special thread lengths can be specified and easily manufactured. Top hex (-HX) and slot standard (-SL) on some sizes. Top slot can be added to any item, add (-SL) to part number.

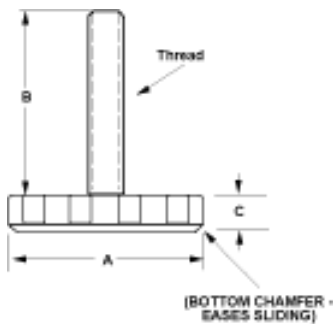

Top Hex (-HX) and Slot (-SL)

Threaded Nylon Knob Hubs/Sleeves

These glass-filled black nylon threaded knob hubs can be used for many applications; as an adjustable height shoulder on a knob or leveler or stacked to create a sleeve to hide the threads of a leveler or knob. This will also help stabilize loads positioned near the top threads of long studs. They can also be used by themselves to create a "thru-hole" knob or as a locking nut.



* Patent Pending



Many colors available as custom option.

Steel	SS	Load	Thread	A	B	C
Steel and Stainless Steel Knob Style Glides						
IL88-4Bx1/4	IL88-4BSx1/4	100	1/4-20	3	1/4	3/8
IL88-4Bx1/2	IL88-4BSx1/2	100	1/4-20	3	1/2	3/8
IL88-4Bx1/2-HX-SL		100	1/4-20	3	1/2	3/8
IL88-4Bx3/4	IL88-4BSx3/4	100	1/4-20	3	3/4	3/8
IL88-4Bx3/4-HX-SL		100	1/4-20	3	3/4	3/8
IL88-4Bx1	IL88-4BSx1	100	1/4-20	3	1	3/8
IL88-4Bx1-HX-SL		100	1/4-20	3	1	3/8
IL88-4Bx125	IL88-4BSx125	100	1/4-20	3	1-1/4	3/8
IL88-4Bx125-HX-SL		100	1/4-20	3	1-1/4	3/8
IL88-4Bx150	IL88-4BSx150	100	1/4-20	3	1-1/2	3/8
IL88-4Bx175	IL88-4BSx175	100	1/4-20	3	1-3/4	3/8
IL88-4Bx175-HX-SL		100	1/4-20	3	1-3/4	3/8
IL88-4Bx2	IL88-4BSx2	100	1/4-20	3	2	3/8
IL88-4Bx275	IL88-4BSx275	100	1/4-20	3	2-3/4	3/8
IL88-5Bx1/4	IL88-5BSx1/4	500	5/16-18	3	1/4	3/8
IL88-5Bx1/2	IL88-5BSx1/2	500	5/16-18	3	1/2	3/8
IL88-5Bx1/2-HX-SL		500	5/16-18	3	1/2	3/8
IL88-5Bx3/4	IL88-5BSx3/4	500	5/16-18	3	3/4	3/8
IL88-5Bx3/4-HX-SL		500	5/16-18	3	3/4	3/8
IL88-5Bx1	IL88-5BSx1	500	5/16-18	3	1	3/8
IL88-5Bx1-HX-SL		500	5/16-18	3	1	3/8
IL88-5Bx125-HX-SL		500	5/16-18	3	1-1/4	3/8
IL88-5Bx125	IL88-5BSx125	500	5/16-18	3	1-1/4	3/8
IL88-5Bx175	IL88-5BSx175	500	5/16-18	3	1-3/4	3/8
IL88-5Bx175-HX-SL		500	5/16-18	3	1-3/4	3/8
IL88-5Bx225-HX-SL		500	5/16-18	3	2-1/4	3/8
IL88-6Bx1/4	IL88-6BSx1/4	1000	3/8-16	3	1/4	3/8
IL88-6Bx1/2	IL88-6BSx1/2	1000	3/8-16	3	1/2	3/8
IL88-6Bx1/2-HX-SL		1000	3/8-16	3	1/2	3/8
IL88-6Bx3/4-HX-SL		1000	3/8-16	3	3/4	3/8
IL88-6Bx1	IL88-6BSx1	1000	3/8-16	3	1	3/8
IL88-6Bx1-HX-SL		1000	3/8-16	3	1	3/8
IL88-6Bx125	IL88-6BSx125	1000	3/8-16	3	1-1/4	3/8
IL88-6Bx125-HX-SL		1000	3/8-16	3	1-1/4	3/8
IL88-6Bx150	IL88-6BSx150	1000	3/8-16	3	1-1/2	3/8
IL88-6Bx175-HX-SL		1000	3/8-16	3	1-3/4	3/8
IL88-6Bx175	IL88-6BSx175	1000	3/8-16	3	1-3/4	3/8
IL88-6Bx238	IL88-6BSx238	1000	3/8-16	3	2-3/8	3/8
IL88-6Bx238-SL		1000	3/8-16	3	2-3/8	3/8
IL88-6Bx238-HX-SL		1000	3/8-16	3	2-3/8	3/8
IL88-6Bx275-HX-SL		1000	3/8-16	3	2-3/4	3/8
IL88-6Bx338-HX-SL		1000	3/8-16	3	3-3/8	3/8
IL88-7Bx3/4	IL88-7BSx3/4	1000	1/2-13	3	3/4	3/8
IL88-7Bx1	IL88-7BSx1	1000	1/2-13	3	1	3/8
IL88-7Bx125	IL88-7BSx125	1000	1/2-13	3	1-1/4	3/8
IL88-7Bx150	IL88-7BSx150	1000	1/2-13	3	1-1/2	3/8
IL88-7Bx238		1000	1/2-13	3	2-3/8	3/8

BLACK NYLON THREADED KNOB HUBS

P/N	THREAD	DIA.	HEIGHT
IL80-HUB-4	1/4-20	1"	3/8
IL80-HUB-5	5/16-18	1"	3/8
IL80-HUB-6	3/8-16	1"	3/8
IL80A-HUB-4	1/4-20	1"	3/4
IL80A-HUB-5	5/16-18	1"	3/4
IL80A-HUB-6	3/8-16	1"	3/4